

SPECIAL AGENDA
BOARD OF RECREATION AND PARK COMMISSIONERS
OF THE CITY OF LOS ANGELES

Wednesday, May 21, 2014 at 9:30 a.m.

Cypress Recreation Center
2630 Pepper Avenue
Los Angeles, CA 90065

LYNN ALVAREZ, PRESIDENT
IRIS ZUÑIGA, VICE PRESIDENT
KAFI D. BLUMENFIELD, COMMISSIONER
SYLVIA PATSAOURAS, COMMISSIONER
MISTY M. SANFORD, COMMISSIONER

EVERY PERSON WISHING TO ADDRESS THE COMMISSION MUST COMPLETE A SPEAKER'S REQUEST FORM AT THE MEETING AND SUBMIT IT TO THE COMMISSION EXECUTIVE ASSISTANT PRIOR TO THE BOARD'S CONSIDERATION OF THE ITEM.

PURSUANT TO COMMISSION POLICY, COMMENTS BY THE PUBLIC ON AGENDA ITEMS WILL BE HEARD ONLY AT THE TIME THE RESPECTIVE ITEM IS CONSIDERED. ALL REQUESTS TO ADDRESS THE BOARD ON PUBLIC HEARING ITEMS MUST BE SUBMITTED PRIOR TO THE BOARD'S CONSIDERATION OF THE ITEM. COMMENTS BY THE PUBLIC ON ALL OTHER MATTERS WITHIN THE SUBJECT MATTER JURISDICTION OF THE BOARD WILL BE HEARD DURING THE "PUBLIC COMMENTS" PERIOD OF THE MEETING

1. INTRODUCTIONS:

Special Introduction and Opening Remarks by Councilmember Gilbert Cedillo, Council District 1, or His Appointed Representative

Kevin Regan, Assistant General Manager, Recreation Operations Branch, will Introduce the Staff of Cypress Recreation Center

2. APPROVAL OF THE MINUTES:

Approval of the Minutes of the Meetings of February 7, 2007, February 21, 2007 and May 7, 2014

3. GENERAL MANAGER'S REPORTS:

14-121 Southeast Valley Roller and Skateboard Rink – Phase I (Skateboard Rink/Skatepark) Project (W.O.#E170125F) – Acceptance of Stop Notice Payment on Construction Contract No. 3387

14-122 St. Andrews Recreation Center – Outdoor Sports Development (W.O. #E170302F) Project – Acceptance of Stop Notice Payment on Construction Contract No. 3446

May 21, 2014

- 14-123 Culver Slauson Recreation Center – Phase II (Youth Community Center) (W.O. #E1907289) Project – Release of Funds Withheld Under Contract No. 3361
- 14-124 North Hollywood Multi-Purpose Intergenerational Center at Tiara Street – New Building and Landscaping (PRJ1543B) (W.O. #E170240F) Project – Release of Money Withheld Under Contract No. 3352
- 14-125 Hansen Dam – Phase II – Ranger Station (W.O. #E170405F) Project and Hollywood Recreation Center – Phase IA – Pool and Pool Building – Demolition (W.O. #E170344F) Project – Final Acceptances
- 14-126 Pan Pacific Park – Proposed Installation of Haym Salomon Commemorative Plaque
- 14-127 Elysian Park – Installation of a Solano Canyon Monument Sign
- 14-128 Clean and Safe Spaces (CLASS) Parks Youth Employment Internship Program – Juvenile Justice Crime Prevention Act After-School Enrichment and Supervision Program for Fiscal Year 2014-2015; Acceptance of Grant Funds
- 14-129 Partnership Division – Partnership Sub-Account for Off-Leash Dog Park Improvement Donations
- 14-130 Various Communications

4. UNFINISHED BUSINESS:

Memorandum: Los Angeles Police Department – Proposed Memorandum of Agreement
Item to be Continued (Original Date – 4/17/13)

14-093 Gilbert Lindsay Community Center – Synthetic Field Replacement (PRJ20806) Project – Allocation of Quimby Fees and Exemption from the the California Environmental Quality Act
Item to be Continued (Original Date – 4/23/14)

14-098 Sunset Gordon Project – Preliminary Authorization to Acquire a Perpetual Easement for Park Purposes; Approval of Final Park Design Plan; Exemption from the California Environmental Quality Act
Item to be Continued (Original Date – 4/23/14)

Oral Report on the communications received by the Department relative to Angel's Knoll Park
(Original Date – 4/23/14)

May 21, 2014

14-120 Griffith Park – Greek Theatre Concession – Request for Proposals for the Operation and Maintenance of the Greek Theatre
(Original Date – 5/7/14)

5. COMMISSION TASK FORCES:

- Commission Task Force on Concessions Report - Commissioners Patsouras and Zuñiga
- Commission Task Force on Facility Repair and Maintenance Report - Commissioners Blumenfield and Sanford

6. GENERAL MANAGER'S ORAL REPORT:

Report on Department Activities and Facilities

7. PUBLIC COMMENTS:

Any comments which require a response or report by staff will be automatically referred to staff for a report at some subsequent meeting.

8. FUTURE AGENDA ITEMS:

Requests by Commissioners to Schedule Specific Items on Future Agendas

9. NEXT MEETING:

The next scheduled meeting of the Board of Recreation and Park Commissioners will be held on Monday, June 2, 2014, 9:30 a.m., at EXPO Center, Comrie Hall, 3980 S. Bill Robertson Lane, Los Angeles, CA 90037.

10. ADJOURNMENT:

Under the California State Ralph M. Brown Act, those wishing to make audio recordings of the Commission Meetings are allowed to bring tape recorders or camcorders in the Meeting.

Sign language interpreters, assistive listening devices, or any auxiliary aides and/or services may be provided upon request. To ensure availability, you are advised to make your request at least 72 hours prior to the meeting you wish to attend. For additional information, please contact the Commission Office at (213)202-2640.

Finalization of Commission Actions: In accordance with City Charter, actions that are subject to Section 245 are not final until the expiration of the next five meeting days of the Los Angeles City Council during which the Council has convened in regular session and if Council asserts jurisdiction during this five meeting day period the Council has 21 calendar days thereafter in which to act on the matter.

Commission Meetings can be heard live over the telephone through the Council Phone system. To listen to a meeting, please call one of the following numbers:

from Downtown Los Angeles	(213) 621-CITY (2489)
from West Los Angeles	(310) 471-CITY (2489)
from San Pedro	(310) 547-CITY (2489)
from Van Nuys	(818) 904-9450

For information, please go to the City's website: <http://ita.lacity.org/ForResidents/CouncilPhone/index.htm>

Information on agenda items may be obtained by calling the Commission Office at (213) 202-2640. Copies of the agenda and reports may be downloaded from the Department's website at www.laparks.org.

REPORT OF GENERAL MANAGER

NO. 14-121

DATE May 21, 2014

C.D. 6

BOARD OF RECREATION AND PARK COMMISSIONERS

SUBJECT: SOUTHEAST VALLEY ROLLER AND SKATEBOARD RINK – PHASE I (SKATEBOARD RINK/SKATEPARK) (W.O #E170125F) PROJECT – ACCEPTANCE OF STOP PAYMENT NOTICE ON CONSTRUCTION CONTRACT NO. 3387

R. Adams	_____	V. Israel	_____
*R. Barajas	<u><i>mf</i></u>	K. Regan	_____
H. Fujita	_____	N. Williams	_____

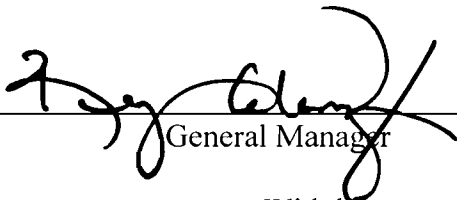

 General Manager

Approved _____ Disapproved _____ Withdrawn _____

RECOMMENDATION:

That the Board direct staff to withhold the amount claimed in the following Stop Payment Notice, plus an additional sum equal to 25% thereof, to defray any costs of litigation in the event of court action, if said amount of said funds are available, and to notify contractors, sureties, and other interested parties that the amount of said claims plus 25% will be withheld.

SUMMARY:

STOP PAYMENT NOTICE:

The Department is in receipt of a legal notice to withhold construction funds, pursuant to California Civil Code Sections 8044, 9100, 9350, 9352, and 9354 on the following contract:

Contract 3387 CD 6

Southeast Valley Roller and Skateboard Rink – Phase I (Skateboard Rink/Skatepark) (W.O #E170125F) Project	General Contractor:	California Landscape and Design, Inc. dba California Skateparks
Project Status: 94 % Complete	Claimant:	Robertson's
Project Impact: none	Amount:	\$1,148.30

REPORT OF GENERAL MANAGER

PG. 2

NO. 14-121

FISCAL IMPACT STATEMENT:

The acceptance of Stop Payment Notice has no impact on the Department's General Fund.

This Report was prepared by Tanzi Cole, Commission Executive Assistant I.

REPORT OF GENERAL MANAGER

NO. 14-122

DATE May 21, 2014

C.D. 8

BOARD OF RECREATION AND PARK COMMISSIONERS

SUBJECT: ST. ANDREWS RECREATION CENTER – OUTDOOR SPORTS DEVELOPMENT (W.O #E1700302F) PROJECT – ACCEPTANCE OF STOP PAYMENT NOTICE ON CONSTRUCTION CONTRACT NO. 3446

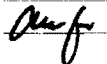
R. Adams	_____	V. Israel	_____
*R. Barajas		K. Regan	_____
H. Fujita	_____	N. Williams	_____

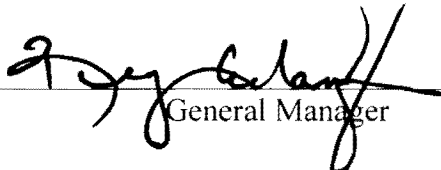

 General Manager

Approved _____ Disapproved _____ Withdrawn _____

RECOMMENDATION:

That the Board direct staff to withhold the amounts claimed in the following Stop Payment Notice, plus an additional sum equal to twenty-five percent (25%) thereof, to defray any costs of litigation in the event of court action, if said amount of said funds are available, and to notify contractors, sureties, and other interested parties that the amount of said claims plus twenty-five percent (25%) will be withheld.

SUMMARY:

STOP PAYMENT NOTICE:

The Department is in receipt of a legal notice to withhold construction funds, pursuant to California Civil Code Sections 8044, 9100, 9350, 9352, and 9354 on the following contract:

<u>Contract 3446</u>	<u>CD 8</u>		
St Andrews Recreation Center – Outdoor Sports	General		Pima Corporation
Development (W.O #E1700302F) Project	Contractor:		
Project Status: Construction	Claimant:		Neff Rental, LLC
Project Impact: None	Amount:		\$4,755.30

FISCAL IMPACT STATEMENT:

The acceptance of Stop Payment Notice has no impact on the Department’s General Fund.

This Report was prepared by Tanzi Cole, Commission Executive Assistant I.

REPORT OF GENERAL MANAGER

NO. 14-123

DATE May 21, 2014

C.D. 11

BOARD OF RECREATION AND PARK COMMISSIONERS

SUBJECT: CULVER SLAUSON RECREATION CENTER – PHASE II (YOUTH COMMUNITY CENTER) (W.O. #E1907289) PROJECT – RELEASE OF FUNDS WITHHELD UNDER CONTRACT NO. 3361

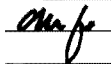
R. Adams	_____	V. Israel	_____
*R. Barajas		K. Regan	_____
H. Fujita	_____	N. Williams	_____

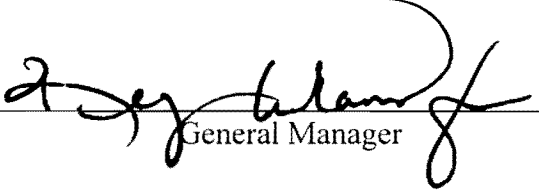

 General Manager

Approved _____

Disapproved _____

Withdrawn _____

RECOMMENDATIONS:

That the Board:

1. Approve the forfeiture of \$38,426.30 on the Culver Slauson Recreation Center – Phase II (Youth Community Center) (W.O. #E1907289) project to Nile Advanced Construction (Nile), Contract No. 3361, for wage restitution and State of California, California Labor Commission, imposed penalties;
2. Authorize the Department’s Chief Accounting Employee to transfer funds, in the amount \$4,477.62, to Revenue Source 4331 - Penalties and Forfeitures, for Fund 100, Department 76 of the City's General Fund;
3. Direct the Department’s Chief Accounting Employee to prepare a draft, in the amount of \$33,948.68, payable to the State of California, and forward the draft to the Department of Public Works, Bureau of Contract Administration, Office of Contract Compliance for processing to the California Labor Commission; and,
4. Authorize the Department’s Chief Accounting Employee to release the remainder of the retention funds held under this contract, in the amount of \$9,014.43, to Nile Advanced Construction, the prime contractor on the project.

REPORT OF GENERAL MANAGER

PG. 2

NO. 14-123

SUMMARY:

The Board of Recreation and Park Commissioners (Board) entered into a construction contract with Nile, Contract No. 3361 on November 2, 2011, to perform work on the Culver Slauson Recreation Center – Phase II (Youth Community Center) (W.O. #E1907289) project,.

A preconstruction conference was held on November 17, 2011 during which the Department of Public Works, Bureau of Contract Administration, Office of Contract Compliance (OCC) reviewed and explained the prevailing wage requirements to Nile and the subcontractors in attendance. Andy Quiocho Concrete (Quiocho) was listed as an approved subcontractor and duly approved by the Board. Quiocho began work on the project site on January 17, 2012.

During the completion of this project, OCC was notified of possible labor violations. After an investigation it was determined that sub-contractor, Quiocho, failed to comply with the labor compliance requirements of the contract. Based on the evaluation of the inspector's logs, certified payroll records, worker interviews, and other pertinent payroll documents, it was determined that Quiocho failed to pay the correct prevailing wage rate and under-reported the number of workers employed on the project. As a result of the evaluation, it was determined that Quiocho underpaid wages by \$33,948.68, and was penalized for such underpayment, in the amount \$4,477.62, for a total of \$38,426.30 in assessed underpayment violations and penalties.

The preliminary investigation by the OCC resulted in evidence indicating Quiocho had underpaid their workers by \$47,440.73. Based on this information, OCC requested that retention funds for the project, for this amount, be withheld to cover all outstanding labor compliance issues on the project. Subsequently, the contractor supplied information which caused OCC to revise the amount of its assessment downward, to \$38,426.30. Department of Public Works, Bureau of Engineering has consulted with the OCC and there are no other wage violations or penalties identified. Therefore, \$9,014.43 of the initially disputed funds is no longer in dispute and it is recommended that \$9,014.43 be released to Nile immediately.

The total amount of wage restitution and state penalties to be forfeited is \$38,426.30, as detailed below:

<u>CONTRACTOR</u>	<u>ALLOCATION</u>	<u>AMOUNT</u>
Nile Construction (on behalf of Quiocho Concrete)	Wage restitution	\$33,948.68
	State penalties	\$4,477.62
Nile Construction	Retention released to contractor	<u>\$9,014.43</u>
TOTAL		\$47,440.73

REPORT OF GENERAL MANAGER

PG. 3

NO. 14-123

FISCAL IMPACT STATEMENT:

There is no fiscal impact to the Department's General Fund, as funds for this project have already been appropriated for this purpose.

This report was prepared by LaTonya D. Dean, Commission Executive Assistant, Department of Recreation and Parks, and revised by Willis Yip, Project Manager, Architectural Division, Department of Public Works, Bureau of Engineering (BOE). Reviewed by Neil Drucker, Program Manager, Recreation and Cultural Facilities Program, BOE, Chris Jenson, Management Analyst II, Department of Public Works, Office of Contract Compliance, Thurman Green, Management Assistant, Department of Public Works, Office of Contract Compliance, and Ted Allen, Acting Deputy City Engineer, Bureau of Engineering.

REPORT OF GENERAL MANAGER

NO. 14-124

DATE May 21, 2014

C.D. 4

BOARD OF RECREATION AND PARK COMMISSIONERS

SUBJECT: NORTH HOLLYWOOD MULTI-PURPOSE INTERGENERATIONAL CENTER AT TIARA STREET – NEW BUILDING AND LANDSCAPING (PRJ1543B) (W.O. #E170240F) PROJECT -- RELEASE OF MONEY WITHHELD UNDER CONTRACT NO. 3352

R. Adams	_____	V. Israel	_____
*R. Barajas	<u><i>mf</i></u>	K. Regan	_____
H. Fujita	_____	N. Williams	_____

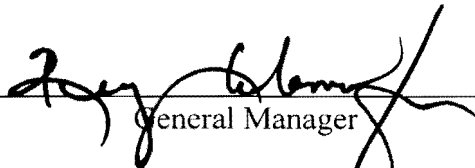

 General Manager

Approved _____

Disapproved _____

Withdrawn _____

RECOMMENDATION:

That the Board immediately release all retention funds, currently held under Contract No. 3352, to Landshapes, inasmuch as the project has been previously accepted as complete by the Board, and Landshapes has made restitution, in the amount of \$651.51, for wage violations identified by the Department of Public Works, Bureau of Contract Administration, Office of Contract Compliance.

SUMMARY:

The City of Los Angeles, a municipal corporation, acting by and through its Board of Recreation and Park Commissioners (Board), entered into a construction contract with Landshapes, Contract No. 3352, on June 23, 2011 to perform work on the North Hollywood Multi-Purpose Intergenerational Center at Tiara Street – New Building and Landscaping (PRJ1543B) (W.O. #E170240F) project.

A preconstruction conference was held on July 12, 2011 during which the Department of Public Works, Bureau of Contract Administration, Office of Contract Compliance (OCC) reviewed and explained the prevailing wage requirements to Landshapes, the Prime Contractor on the project, and the subcontractors in attendance.

REPORT OF GENERAL MANAGER

PG. 2

NO. 14-124

During the completion of this project, OCC was notified of possible labor violations. After an investigation, it was determined that Landshapes failed to comply with the labor compliance requirements of the contract. Based on the evaluation of the inspector's logs, certified payroll records, worker interviews, and other pertinent payroll documents, it was determined that Landshapes failed to pay the correct prevailing wage rates for some workers employed on the project.

The preliminary investigation by the OCC provided results which indicated that Landshapes had underpaid their workers by approximately \$10,000.00. Based on this information, OCC requested that a portion of retention funds already being held for the project, in the amount of \$10,000.00, be withheld to cover all outstanding labor compliance issues on the project. Subsequently, the contractor supplied information which caused OCC to revise the amount of its assessment downward to \$651.51. Landshapes has paid this wage assessment and has settled their prevailing wage issue with OCC. As there are no other remaining project related issues (inspection, engineering, stop notices, mechanics liens, etc.,) the total remaining retention amount should be released to Landshapes, immediately.

FISCAL IMPACT STATEMENT:

There is no fiscal impact to the Department's General Fund, as funds for this project have already been appropriated for this purpose.

This report was prepared by LaTonya D. Dean, Commission Executive Assistant, Department of Recreation and Parks and revised by Dale Kanegawa, Management Analyst I, Department of Public Works, Office of Contract Compliance. The report was reviewed by Neil Drucker, Program Manager, Recreational and Cultural Facilities Program, Department of Public Works, Bureau of Engineering, and Ted Allen, Deputy City Engineer, Department of Public Works, Bureau of Engineering.

REPORT OF GENERAL MANAGER

NO. 14-125

DATE May 21, 2014

C.D. 7 & 13

BOARD OF RECREATION AND PARK COMMISSIONERS

SUBJECT: HANSEN DAM – PHASE II – RANGER STATION (W.O. #E170405F)
PROJECT AND HOLLYWOOD RECREATION CENTER – PHASE IA –
POOL AND POOL BUILDING – DEMOLITION (W.O. #E170344F)
PROJECT – FINAL ACCEPTANCES

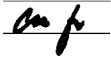
R. Adams	_____	V. Israel	_____
*R. Barajas	<u></u>	K. Regan	_____
H. Fujita	_____	N. Williams	_____

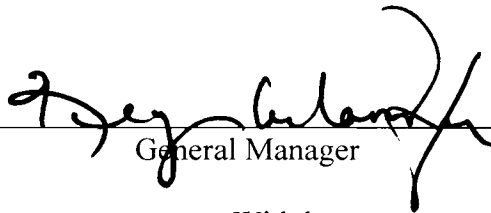
General Manager

Approved _____ Disapproved _____ Withdrawn _____

RECOMMENDATIONS:

That the Board:

1. Approve the final acceptance of the work performed to construct the Hansen Dam – Phase II – Ranger Station (W.O. #E170405F) project, located at 12200 West Osborne Street, Lake View Terrace, California 91342, under the Memorandum of Understanding (MOU), between the Department of Recreation and Parks (RAP), Department of Public Works, Bureau of Engineering (BOE), and the Department of General Services, Construction Forces (GSD), as outlined in the Summary of this Report;
2. Approve the final acceptance of the work performed to the Hollywood Recreation Center – Phase IA – Pool and Pool Building – Demolition (W.O. #E170344F) project, located at 1122 Cole Street, Los Angeles, California 90038, under the MOU with RAP, BOE and GSD, as outlined in the Summary of this Report; and,
3. Authorize the Board Secretary to furnish GSD with letters of completion for the subject projects.

REPORT OF GENERAL MANAGER

PG. 2

NO. 14-125

SUMMARY:

The following two (2) construction projects were awarded to GSD through the approval of MOUs between the RAP, BOE, and GSD.

Hansen Dam – Phase II – Ranger Station (W.O. #E170405F) Project (Council District 7, Proposition K Regional Specified)

The Hansen Dam – Phase II – Ranger Station (W.O. #E170405F) project, called for the construction of a new, single story, 4,600 square foot building. The building includes offices for the park rangers, a visitor center, including the entry point for the patrons of Hansen Dam campgrounds and equestrian trails, public restrooms, a community meeting room, a communication center, lunch room and storage. The project also has park ranger and visitor parking, road improvements including reconfiguration of the park entrance to monitor site access, site grading and landscaping, and new utility connections including an extension of the sewer line. The building roof line extends beyond the building envelope providing a shade structure covering most of the front lawn to allow for outdoor events to be held comfortably.

The project was awarded to GSD on June 17, 2009 (Board Report No. 09-169) for construction. Funds were obligated prior to the end of fiscal year 2008-2009 by way of an executed MOU in order to avoid loss of the Proposition K funds. The MOU amount of \$4,650,000.00 was a budgetary figure provided to GSD and was not based upon a cost estimate developed by GSD. It was recognized at the time of award to GSD that the MOU would have to be amended to reflect the total construction cost, at the time of completion of plans and specifications for the project. Therefore, upon completion of the plans and preparation of a detailed construction cost estimate by GSD, an additional amount of \$1,892,531.00 was approved for transfer to GSD on February 16, 2011 (Board Report No. 11-053), which totaled a not-to-exceed amount of \$6,542,531.00, including a 10% contingency, in the amount of \$594,776.00. Because of the complex design of the project, numerous unforeseen conditions, errors and omissions in design as well as GSD's construction cost estimate, additional funding was transferred to GSD, in an amount of \$907,469.00, for a total not-to-exceed amount of \$7,450,000.00. Funding was approved by the L.A. for Kids Steering Committee on May 30, 2013 and an amendment to the supplemental MOU was approved by RAP Board on November 6, 2013 (Board Report No. 13-275).

GSD completed the project on November 30, 2013, and the quality of the work is excellent. There is no contract compliance or labor issues with the work done under this MOU, because the construction work was completed by City employees.

REPORT OF GENERAL MANAGER

PG. 3

NO. 14-125

Hollywood Recreation Center – Phase IA – Pool and Pool Building – Demolition (W.O. #E170344F) Project (Council District 13, Proposition K Specified)

The Hollywood Recreation Center - Phase IA – Pool and Pool Building – Demolition (W.O. #E170344F) project, located at 1122 Cole Street, Los Angeles, California 90038, called for the demolition of the existing pool and pool building in order to construct a modern gym and pool buildings. The Hollywood Recreation Center – Phase IA – Pool and Pool Building – Demolition (W.O. #E170344F) project was funded by Proposition K.

On May 16, 2012, the project was awarded to GSD for demolition (Board Report No. 12-146). Based on a BOE estimate for the cost of demolition, the approved funding amount was set at \$500,000.00, including a \$50,000.00 contingency.

The demolition was finished in April 2013 and the quality of work is excellent. The total cost of Hollywood Recreation Center – Phase IA – Pool and Pool Building – Demolition (W.O. #E170344F) project was \$359,517.62. The remaining funding will be returned to the project account. There is no contract compliance or labor issues with the work done under this MOU, because the demolition work was completed by City employees.

The table below has final project information for both projects. There were no change orders issued on either project.

Project Name	Address	RAP Project No.	BOE Work Order No.	Construction Completion Date	Original Construction Cost	Total Change Order Amount	Total Construction Costs
Hansen Dam - Phase II - Ranger Station project	12200 West Osborne Street, Pacoima, CA 91331		E170405F	11/30/2013	\$7,450,000.00	N/A	\$7,450,000.00
Hollywood Recreation Center - Phase IA – Pool and Pool Building – Demolition project	1122 Cole Ave. Los Angeles, CA 90038	PRJ 1402B	E170344F	4/2013	\$500,000.00	N/A	\$359,517.62

REPORT OF GENERAL MANAGER

PG. 4

NO. 14-125

FISCAL IMPACT STATEMENT:

Hansen Dam - Phase II - Ranger Station (W.O. #E170405F) Project

At this time, there is no fiscal impact to RAP's General Fund due to \$14,050.00 requested and received in Fiscal Year 2012-2013 for part time maintenance staff funding.

Hollywood Recreation Center - Phase IA - Pool and Pool Building - Demolition (W.O. #E170344F) Project

At this time, there is no fiscal impact to the RAP's General Fund for the approval of this Report. RAP currently operates this facility and operating budgets are in place. However, future operational maintenance costs will be determined and a request for funding will be submitted in future Department annual budget requests.

This Report was prepared by Sean Phan and Shashi Bhakta, Project Managers, Recreational and Cultural Facilities Program. Reviewed by Neil Drucker, Program Manager, BOE, Recreational and Cultural Facilities Program; Ted Allen, P.E., Acting Deputy City Engineer, BOE and Cathie Santo Domingo, Superintendent, of Planning, Construction and Maintenance Branch, Department of Recreation and Parks.

REPORT OF GENERAL MANAGER

NO. 14-126

DATE May 21, 2014

C.D. 4

BOARD OF RECREATION AND PARK COMMISSIONERS

SUBJECT: PAN PACIFIC PARK – PROPOSED INSTALLATION OF HAYM SALOMON
COMMEMORATIVE PLAQUE

R. Adams	_____	V. Israel	_____
*R. Barajas	<u><i>amf</i></u>	K. Regan	_____
H. Fujita	_____	N. Williams	_____

Haym Salomon
General Manager

Approved _____ Disapproved _____ Withdrawn _____

RECOMMENDATIONS:

That the Board:

1. Approve the installation of a commemorative plaque at the foot of the Haym Salomon Statue currently located at Pan Pacific Park, as described in the Summary of this Report; and,
2. Authorize the Department of Recreation and Parks to issue a Right-of-Entry permit to the Los Angeles - Escholtzia Chapter of the Daughters of the American Revolution.

SUMMARY:

The Los Angeles - Escholtzia Chapter of the Daughters of the American Revolution (LA-DAR), has proposed to install a commemorative plaque in front of the existing statue of Haym Salomon located at Pan Pacific Park. The proposed plaque would supplement the statue and associated markers with a narrative that describes Mr. Salomon's contribution to the American Revolutionary War. Haym Salomon is not well known and the current statue and markers do not describe who Mr. Salomon was as an American Jewish Patriot.

LA-DAR is the second oldest California chapter of the Daughters of the American Revolution (DAR). It is a non-profit, non-political volunteer women's service organization dedicated to promoting patriotism, preserving American history, and securing America's future through better education for children. Any woman 18 years of age or older - regardless of race, religion, or ethnic background - who can prove lineal descent from a patriot of the American Revolution, is eligible for membership.

REPORT OF GENERAL MANAGER

PG. 2 NO. 14-126

Mr. Haym Salomon was a Polish born Jewish immigrant to America who played an important role in financing the American Revolutionary War. He was a financial broker in New York City when he was arrested by the British as a spy in 1776. He was pardoned and used by the British as an interpreter with their German troops. Mr. Salomon, however, continued to help prisoners of the British escape and encouraged German troops to desert. He was arrested again in 1778 and sentenced to death. But he was able to escape to the “rebel” capital of Philadelphia, where he resumed his career as a broker and dealer in securities. He also became broker to the French consul and paymaster to French troops in America. At the time of Mr. Salomon’s arrival in Philadelphia, the Continental Congress was struggling to raise money to support the war. Congress had no powers of direct taxation and had to rely on requests for money directed to the states. The government had no choice but to borrow money and was ultimately bailed out by loans from the French and Dutch governments. From 1781 on, Mr. Salomon brokered bills of exchange for the American government and extended interest-free loans to members of Congress.

The existing Haym Salomon statue was executed by Robert Paine in 1943 and installed at the Department of Recreation and Parks’ (Department) MacArthur Park in 1944. In 1983, at the request of the Jewish War Veterans of the United States (Los Angeles County Council), the statue was relocated to its current location in Pan Pacific Park (see Exhibit A).

The proposed commemorative plaque measures approximately 20”x 26” which will be on top of a 24”x 30” pedestal sitting on a 36”x 40” base (see Exhibits B1-B3). The plaque will be cast in bronze with a raised single line border with an arched top. The DAR emblem will be located in the arch. It will have Times Roman lettering with dark brown colored, leatherette textured background. The pedestal will be made of Halila honed limestone, which is a durable stone indigenous to Israel and is intended as a homage to Haym Salomon’s Jewish roots. The base will be made of concrete. The entire assemblage described above is proposed to be placed in front of the current statue as depicted in Exhibit C.

The proposed commemorative plaque will include the following inscription:

HAYM SALOMON
1740-1785

A Jewish immigrant from Lezno, Poland, Haym Salomon arrived in New York City in the years preceding the Revolutionary War. He was arrested by the British as a spy. Following his escape, he assisted the Continental Army as a purveyor to soldiers. He provided supplies and financial assistance while travelling with the troops withdrawing from New York. After moving the family to Philadelphia, he became a broker for the Office of Finance under the Superintendent of Finance, Robert Morris. Fluent in several languages, Salomon was invaluable in negotiating the sale of war aid from European countries including France and Holland.

REPORT OF GENERAL MANAGER

PG. 3 NO. 14-126

Haym Salomon contributed most of his personal effects and financial holdings to the American Revolution. He died January 6, 1785 in Philadelphia, PA.

“Gentleman, scholar, patriot, and banker, whose only interest was the interest of his country”

Congress Report 1936
Marker place by the
Los Angeles-Eschscholtzia Chapter
National Society Daughters of the American Revolution
DATE

There will be no cost to the Department for installation of the proposed commemorative plaque. All associated costs will be borne by the LA-DAR, who will arrange for the installation after the issuance of the appropriate Right-of-Entry permit. The applicant has agreed to maintain the plaque to the satisfaction of the Department in addition to signing a waiver which allows for the removal of the plaque, at the sole discretion of the Department, if not maintained to Department standards.

The Cultural Affairs Commission may have to also authorize installation of the proposed commemorative plaque. Should it be required, Cultural Affairs Commission approval will be obtained prior to the issuance of the Right of Entry permit.

Staff has determined that the subject project is exempt from the provisions of the California Environmental Quality Act (CEQA) pursuant to Article VII, Section 1, Class 1 (1) of the City CEQA Guidelines.

Council District 4 and Pacific Region management and staff support this project at Pan Pacific Park.

FISCAL IMPACT STATEMENT:

There will be negligible impact to the Department’s General Fund due to LA-DAR’s commitment to bearing all costs associated with the design, installation and maintenance of the commemorative plaque and the ability to remove the plaque if necessary.

This Report was prepared by Melinda Gejer, Planning Associate and reviewed by Cid Macaraeg, Sr. Management Analyst II, Planning, Construction and Maintenance Branch.

Exhibit A



FOXSTONE HALILA HONED

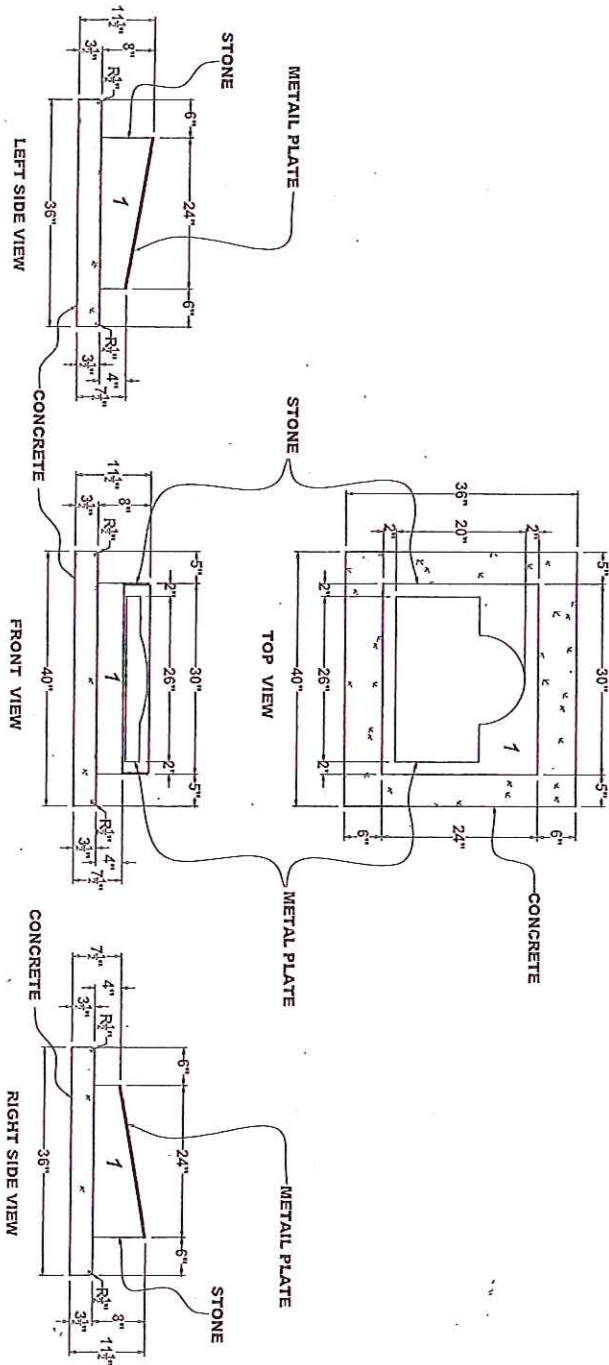

**FOXSTONE
HALILA HONED**

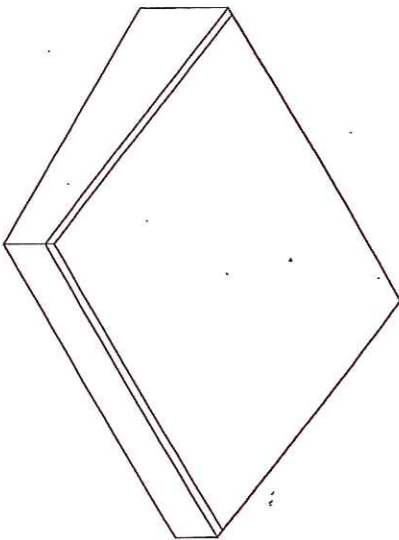
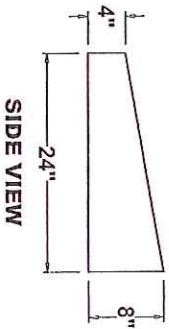
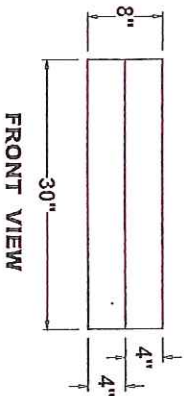
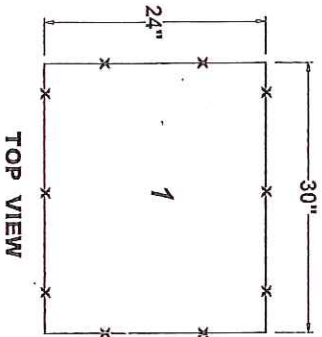

3D VIEW

Exhibit B3

FOXSTONE HALILA HONED

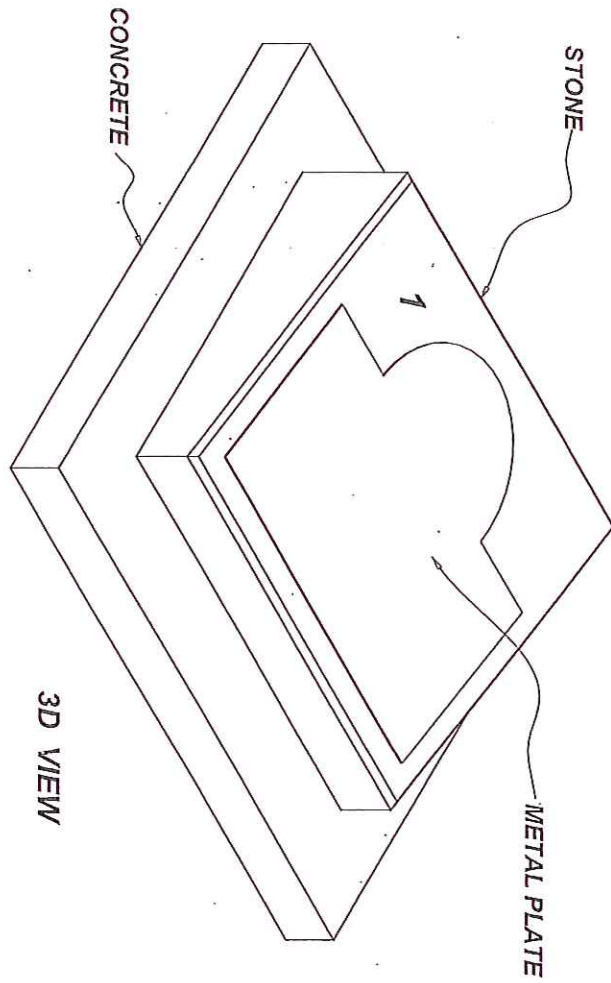
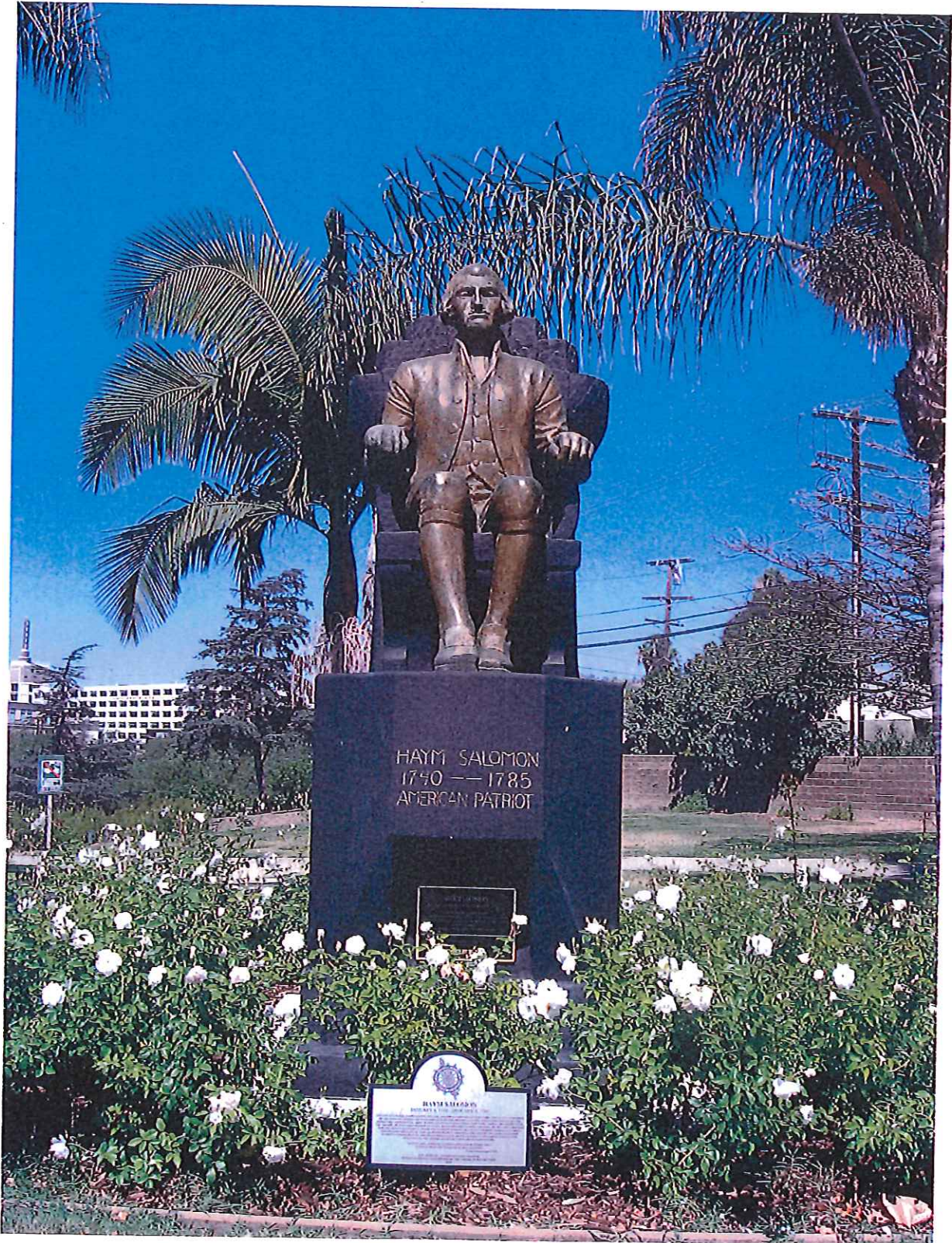

Exhibit C



REPORT OF GENERAL MANAGER

NO. 14-127

DATE May 21, 2014

C.D. 13

BOARD OF RECREATION AND PARK COMMISSIONERS

SUBJECT: ELYSIAN PARK – INSTALLATION OF A SOLANO CANYON MONUMENT SIGN

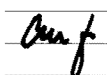
R. Adams	_____	V. Israel	_____
*R. Barajas		K. Regan	_____
H. Fujita	_____	N. Williams	_____

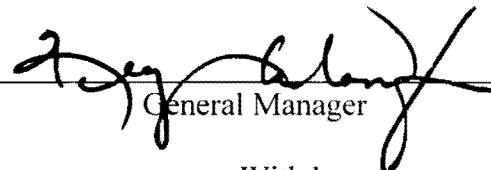

 General Manager

Approved _____ Disapproved _____ Withdrawn _____

RECOMMENDATIONS:

That the Board:

1. Approve the installation of a Solano Canyon Monument Sign at the southwest corner of the intersection of Amador Street and Solano Avenue in Elysian Park, as shown in Attachment A;
2. Approve the design and wording of the sign, as illustrated in Attachment B; and
3. Authorize Department of Recreation and Parks (Department) staff to issue a Right-of-Entry permit to Paradise Signs, Inc., for the installation of the sign as indicated.

SUMMARY:

Solano Canyon is a small community located within the boundaries of Elysian Park. Solano Canyon is the last remaining residential community within Elysian Park since the removal of several other neighborhoods in preparation for the installation of Dodger Stadium in the mid 1950's. The Historic Cultural Neighborhood Council (HCNC) of downtown Los Angeles has proposed the installation of a Solano Canyon Monument Sign. The sign would be installed at the southwest corner of the intersection of Amador Street and Solano Avenue in Elysian Park, located at 498 Solano Avenue, Los Angeles, California 90012 (Attachment A). The proposed location is on a 0.10 acre portion of Elysian Park which was donated to the City of Los Angeles in 2008. (Board Report No. 08-344).

REPORT OF GENERAL MANAGER

PG. 2 NO. 14-127

This Solano Canyon Monument Sign will mark the southeast entrance to this historic neighborhood on the southern boundary of Elysian Park. The Citizens Committee to Save Elysian Park (CCSEP) voted to accept the Solano Canyon Monument Project in October 2007. Additionally, the HCNC granted approval of the Solano Canyon Monument Project in November 2007 and has agreed to provide funding for the design, manufacture, installation, and maintenance of the sign.

The proposed Solano Canyon Monument Sign will compliment a previously installed Monument Project Sign from 2008 (Board Report No. 08-203). The sign will be composed of a precast concrete panel with recessed letters and river rock. The sign will be approximately 2.5 feet in height and 8 feet wide (Attachment B). The design elements of the proposed sign do not conflict with the Master Plan for Elysian Park.

Staff has determined that the subject project is exempt from the provisions of the California Environmental Quality Act (CEQA), pursuant to Article III, Section 1, Class 11(1), of the City CEQA Guidelines.

FISCAL IMPACT STATEMENT:

There will be negligible fiscal impact on the Department's General Fund. The sign will have minimal maintenance requirements. Foreseeable vandalism repair costs will be covered by a \$1,000.00 donation to the Department by HCNC. The funds earmarked for vandalism repair will be placed in Fund 302, Department 89, Account 89832M, Metro Region Donation account. HCNC has also agreed to cover the cost of the design, manufacture, and installation of the sign.

This Report was prepared by Melinda Gejer, City Planning Associate, Planning, Construction and Maintenance Branch.

Attachment A - Proposed Sign Location

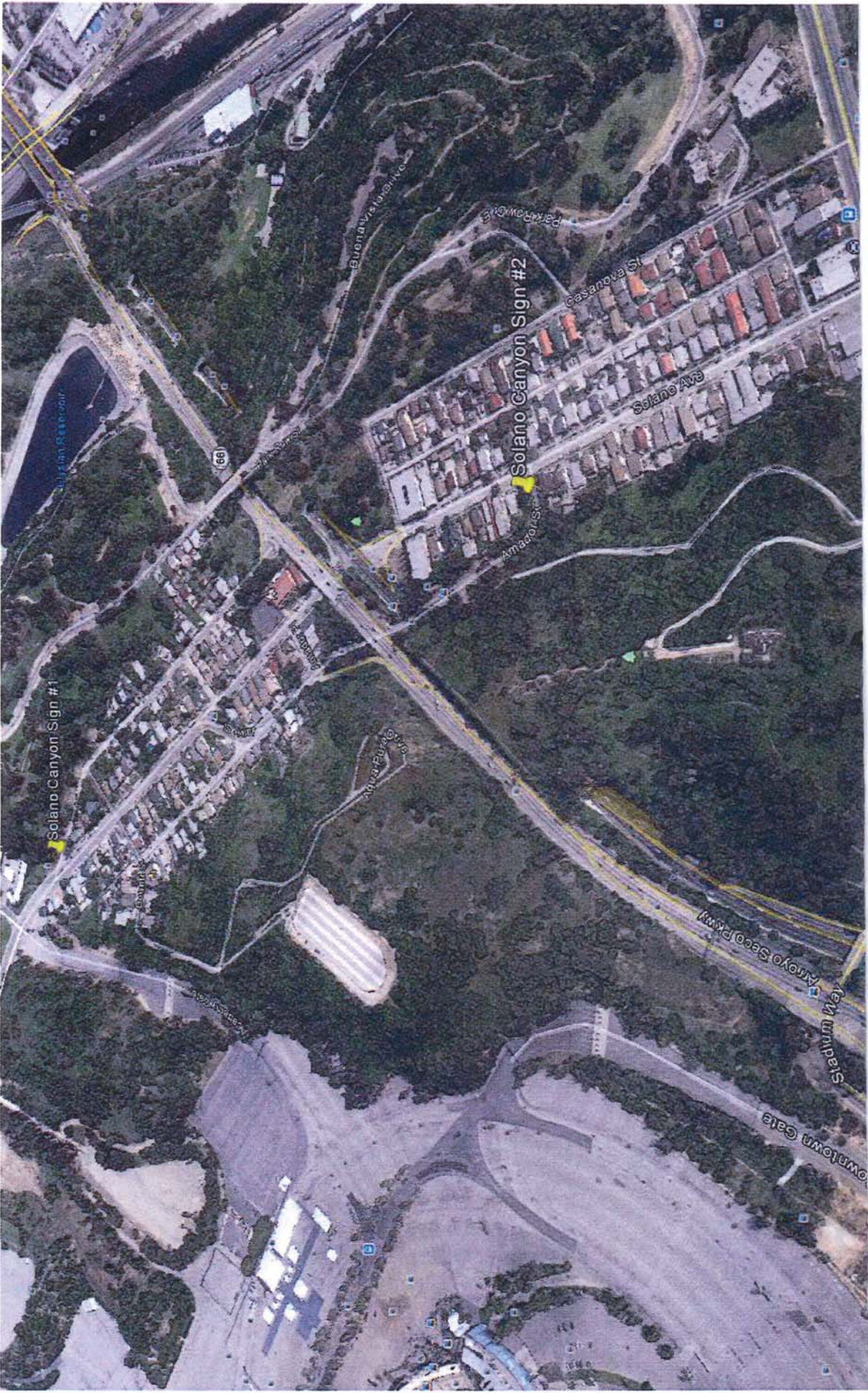

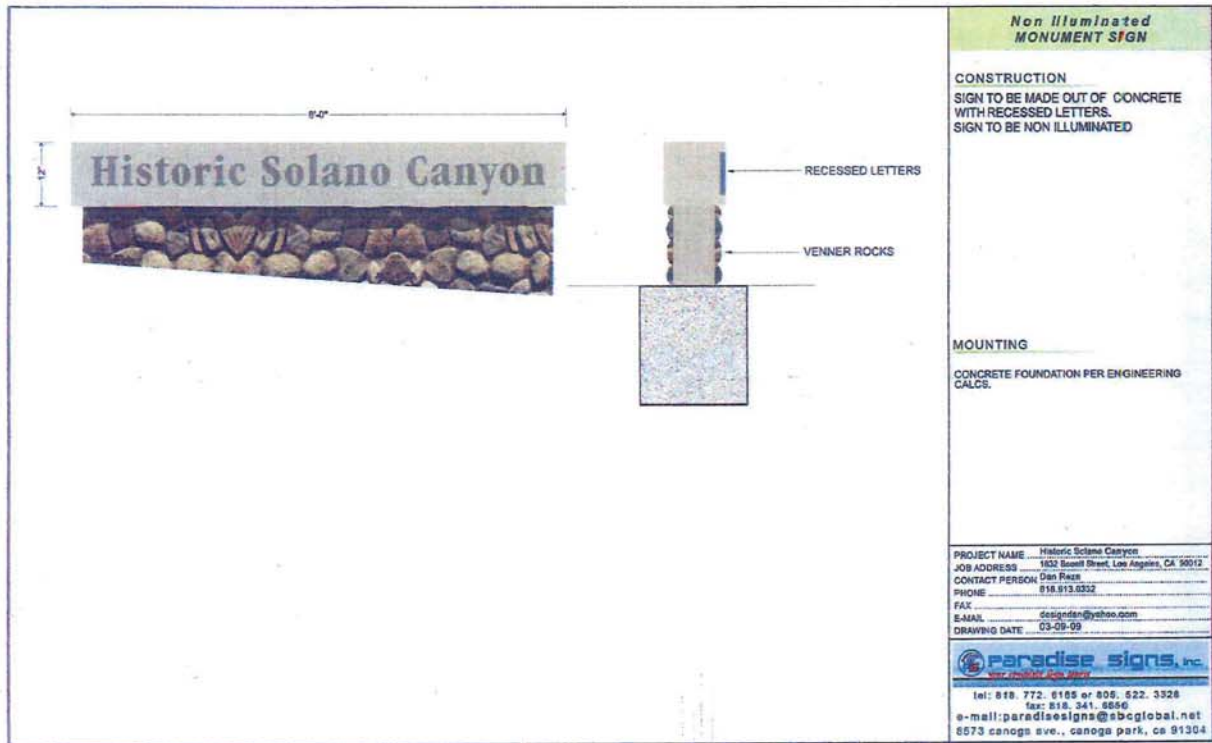

Proposed Design for Solano Canyon Monument Sign #2



Previously Installed Solano Canyon Monument Sign #1

REPORT OF GENERAL MANAGER

NO. 14-128

DATE May 21, 2014

C.D. Various

BOARD OF RECREATION AND PARK COMMISSIONERS

SUBJECT: CLEAN AND SAFE SPACES (CLASS) PARKS YOUTH EMPLOYMENT INTERNSHIP PROGRAM – JUVENILE JUSTICE CRIME PREVENTION ACT AFTER-SCHOOL ENRICHMENT AND SUPERVISION PROGRAM FOR FISCAL YEAR 2014-2015; ACCEPTANCE OF GRANT FUNDS

R. Adams _____
R. Barajas _____
H. Fujita _____

V. Israel _____
*K. Regan _____
N. Williams _____

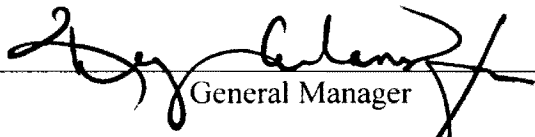

General Manager

Approved _____

Disapproved _____

Withdrawn _____

RECOMMENDATIONS:

That the Board:

1. Authorize the Department of Recreation and Parks' (RAP) General Manager to accept and receive Juvenile Justice Crime Prevention Act (JJCPA) (formerly known as the Schiff-Cardenas Crime Prevention Act) grant funding in the approximate amount of \$504,430.00 from the Los Angeles County Probation Department (County) to provide youth services through the Clean and Safe Spaces (CLASS) Parks Youth Employment Internship Program (YEIP) during specified hours of peak juvenile criminal occurrences for a fourteenth fiscal year (2014-2015) at selected recreational facilities, subject to the approval of the Mayor and City Council;
2. Direct staff to transmit a copy of the grant award to the Mayor, Office of the City Administrative Officer (CAO), Office of the Chief Legislative Analyst (CLA) and to the City Clerk for committee and City Council approval before accepting and receiving the grant award, pursuant to Los Angeles Administrative Code Section 14.6 et seq. as may be amended;
3. Designate RAP's General Manager, Executive Officer, or Assistant General Manager, as the agent to conduct all negotiations, execute and submit all documents, including, but not limited to applications, agreements, amendments, and payment requests, which may be necessary for the completion of the program; and

REPORT OF GENERAL MANAGER

PG. 2 NO. 14-128

4. Authorize RAP's Chief Accounting Employee to establish the necessary account and/or to appropriate funding received within "Recreation and Parks Grant" Fund 205 to accept the JJCPA grant funds in the approximate amount of \$504,430.00 for the CLASS Parks YEIP.

SUMMARY:

The Los Angeles County Probation Department (County) awards and administers funding for the State's JJCPA grant funding. Over the past thirteen (13) years, the Department of Recreation and Parks (RAP) has received over \$7 million in JJCPA funding to continue programs designed to serve at-risk youth through the Clean and Safe Spaces (CLASS) Parks Youth Employment Internship Program (YEIP). This program provides participants with positive activities and alternatives for new learning experiences.

In April 2014, the County recommended funding RAP's CLASS Parks YEIP for Fiscal Year 2014-2015 for the period covering July 1, 2014 through June 30, 2015. These funds will allow staff to continue the Camp Counseling and Leadership Training, Sports Management and Leadership Training, Crime Scene Investigation, and After School Programming. These programs have been approved through various board reports related to the JJCPA Grant.

FISCAL IMPACT STATEMENT:

This grant is administered on a reimbursement basis from the County to allow RAP the ability to negotiate services in a timely manner. RAP may realize a financial benefit as participants, who successfully complete the Camp Counselor Leadership Training Program, begin to serve as volunteers at various RAP facilities. There is no fiscal impact to RAP's General Fund.

This report was prepared by Frank Herrera, Acting Principal Recreation Supervisor I, CLASS Parks.

REPORT OF GENERAL MANAGER

NO. 14-129

DATE: May 21, 2014

C.D. All

BOARD OF RECREATION AND PARK COMMISSIONERS

SUBJECT: PARTNERSHIP DIVISION - PARTNERSHIP SUB-ACCOUNT FOR OFF-LEASH DOG PARK IMPROVEMENT DONATIONS

R. Adams	_____	*V. Israel	
R. Barajas	_____	K. Regan	_____
H. Fujita	_____	N. Williams	_____

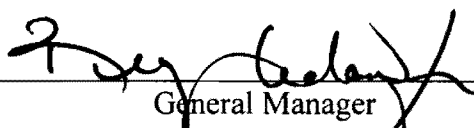

 General Manager

Approved _____ Disapproved _____ Withdrawn _____

RECOMMENDATION:

That the Board direct the Department of Recreation and Parks (RAP) Chief Accounting Employee to establish in Fund 302, Department 89, Account 89708H (Donations), a sub-account to be determined for receipt of donations generated to fund minor improvements and support maintenance staff at any of the various off-leash Dog Parks managed by RAP, to deposit all such donated funds into the sub-account, and to pay donation-specified expenses related to off-leash dog park improvements and maintenance from said sub-account.

SUMMARY:

In accordance with the Board's Policy on Partnerships, RAP's Partnership Division identifies collaborative opportunities, including donations, sponsorships, and operating agreements, all to the benefit of the community by enhancing and expanding services. On November 7, 2012, the Board authorized RAP's Chief Accounting Employee to establish Partnership accounts in Fund 302/89 by category, then to create sub-accounts under each category as needed to receive funds generated from the Partnership Division work activities (Report No. 12-310).

Recently, the Partnership Division has been working on a series of solicitation ideas for RAP's off-leash exercise areas for dogs and their owners, colloquially known as "Dog Parks." The provision and maintenance of the Dog Parks represents a facility category that serves a specific clientele and presents maintenance challenges different than a typical park. Many of RAP's nine (9) off-leash Dog Parks have active volunteer organizations which help collaboratively manage daily activity and monitor owner compliance with the Board's official Dog Park regulations. These groups also may spearhead efforts to improve maintenance of the dog parks and enhance the environs. For example, park users at the Silver Lake Dog Park have supported

REPORT OF GENERAL MANAGER

PG. 2 NO. 14-129

the addition of RAP installed shade structures, and are interested in raising donations to help maintain the shade structures and in other ways provide better maintenance to the Dog Park. The size of these donations is under \$5,000.00. However, in addition a local business has offered to match such donations possibly raising the potential figure to \$10,000.00. Other potential projects under development by the Partnership Division include possible sponsorship, such as exchanging monetary and in-kind contributions for recognition signage, and other small enhancement ideas such as benches, water fountains for persons and dogs, and more trees at various Dog Parks, depending on facility needs and the community input.

The recommended sub-account will be used to receive these types of small donations, which will be acknowledged through Board Reports. A sub-account for deposit of revenue accrued through donations for off-leash Dog Park needs is recommended for transparency of purpose and ease of tracking. By using a separate sub-account, expenditures are directly associated with the minor Dog Park improvements and maintenance programs for which funds were donated. In the case of any future major program or capital improvement gift, staff would request establishment of a new, project- and site-specific sub-account.

FISCAL IMPACT STATEMENT:

The establishment of sub-account for deposit of donations to support maintenance and minor improvements of off-leash dog parks will have no fiscal impact on RAP's General Fund.

This report was prepared by Joel Alvarez, Senior Management Analyst I, Partnership Division.

REPORT OF GENERAL MANAGER

NO. 14-130

DATE May 21, 2014

C.D. Various

BOARD OF RECREATION AND PARK COMMISSIONERS

SUBJECT: VARIOUS COMMUNICATIONS

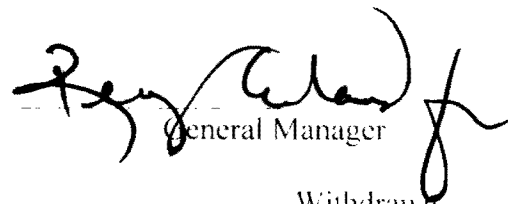

General Manager

Approved

Disapproved

Withdrawn

The following communications have been received by the Board and recommended action thereon is presented.

From:

Recommendation:

1) Mayor, relative to a proposed Agreement with Carl Zeiss AG for the maintenance of the Star Projector at Griffith Observatory.

Referred to staff for further processing.

2) City Clerk, relative to the reallocation of uncommitted Los Angeles County Safe Neighborhood Parks Propositions of 1992 and 1996 funds (Propositions A-I and A-II, respectively).

Referred to General Manager.

3) City Clerk, relative to improvements to Hazard Park under the responsibility of the Los Angeles Parks Foundation.

Referred to General Manager.

4) Chief Legislative Analyst, forwarding the Legislative Report for the weeks ending April 4, and April 11, 2014.

Note and File.

REPORT OF GENERAL MANAGER

PG. 2

NO. 14-130

- 5) Victor June Ayala, to Christine Abbott, Recreation Facility Director, relative to the basketball courts at Rose Hill Recreation Center. Note and File.
- 6) Matthew Lux, Vice President, CBRE, relative to sites for Top Golf facilities. Referred to General Manager.
- 7) Sierra Club Angeles Chapter Verdugo Hills Conservation Roundtable, relative to how the Board handled the Griffith Park Crystal Springs New Baseball Fields (W.O. #E170110B) project. Note and File.
- 8) Don Geier, to Councilmember Bonin, relative to smoking at Venice Beach Boardwalk. Note and File.
- 9) Pedro Santana Jr., relative to a referee's call in a game supervised by Municipal Sports. Referred to General Manager.
- 10) Six residents, eight communications relative to Beachwood Drive. Referred to General Manager.
- 11) Rick Selan, two communications relative to the Venice Neighborhood Council. Note and File.
- 12) Brandon Gaither, Junior Sales Development Representative, TeamSnap, relative to managing sports teams. Referred to General Manager.
- 13) Leigh, relative to the rubber track at Rancho Cienega Sports Center. Referred to General Manager.

This report was prepared by Paul Liles, Clerk Typist, Commission Office.

MATTERS PENDING

Matters Pending will be carried for a maximum of six months, after which time they will be deemed withdrawn and rescheduled whenever a new staff report is received.

GENERAL MANAGER'S REPORTS:

<u>ORIGINALLY PLACED ON BOARD AGENDA</u>	<u>PLACED ON MATTERS PENDING</u>	<u>DEEMED WITHDRAWN</u>
--	--	-----------------------------

None

BIDS TO BE RECEIVED:

None

PROPOSALS TO BE RECEIVED:

6/10/14	Operation and Maintenance of The Lummis House
7/15/14	Griffith Park Halloween Event

QUALIFICATIONS TO BE RECEIVED:

None